

Lightwave

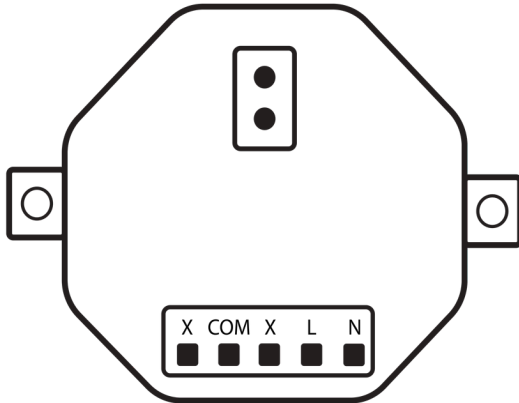

## Installation Manual

Smart Relay with  
Open/Stop/Close (LP82)

# Table Of Contents

Section	Page
Installation Support.....	3
General Information.....	4
Product Dimensions .....	5
Technical Specifications.....	6
Preparing for Installation.....	7
Installing a Smart Relay with Open/Stop/Close (LP82) .....	8
Installing a Smart Relay to a Lightwave dimmer switch.....	12
How to pair a Smart Relay to the Lightwave App .....	13
How to Create a Group Automation for a Dimmer Switch and Relay in the Lightwave App .....	15
Creating Automations .....	16
Troubleshooting .....	17
Feedback.....	19

## Installation Support

In this booklet you will find wiring diagrams and instructions on how to set up a Smart Relay with Open/Stop/Close (LP82).

For further guidance click on the links below:

[Contact the technical support team](#)

[Contact a Lightwave Pro installer](#)

[Have a look at our website](#)

[Phone number: 0121 468 8987](#)

# General Information

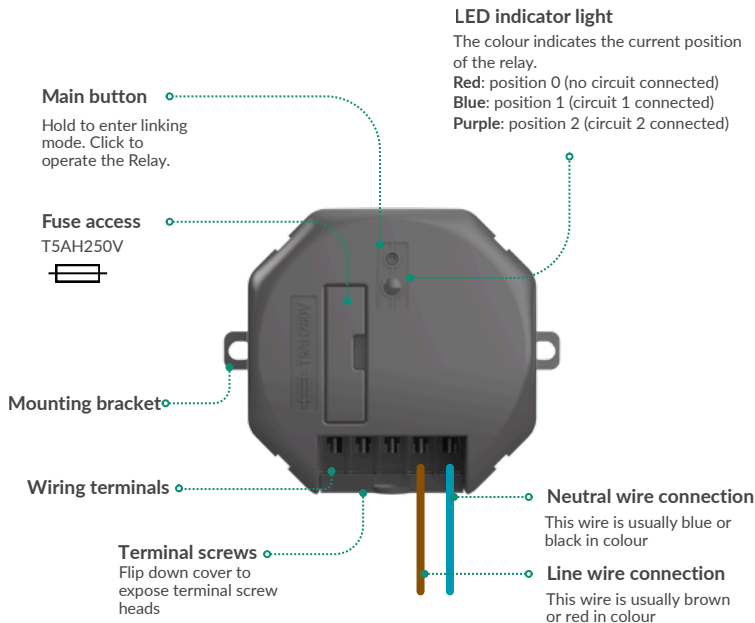

**RF frequency:**  
868 MHz

**Voltage and Frequency:**  
230V ~ 50Hz

**Standby energy use:**  
Less than 1W

**Terminals:**  
Max 1.5mm<sup>2</sup> wires

**Housing:**  
Separate class II housing required

## Usage and Setup:

- Can be used outdoors with a Waterproof Housing
- Controls garden lighting, pumps, gates, curtains, doors, extractor fans & more
- Avoid placing near large metal objects or water to ensure reliable wireless communication
- Three latching positions allow on/off and stop functions (can switch between two circuits)

## Loading:

- Controls devices up to 500W
- Works with mains or low voltage systems
- Can also supply power to the circuit if needed

## Warranty:

- 2-year standard warranty (from the date of purchase).
- A lifetime warranty on the device is available if you are a Lightwave Plus member.

## Product Dimensions

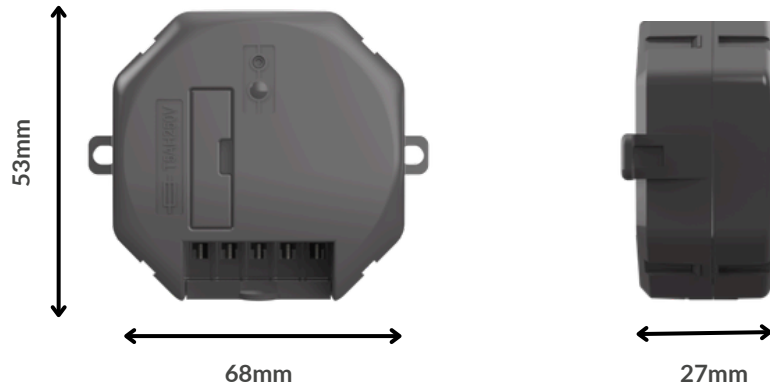

Height: 53mm

Width: 68mm

Depth: 27mm

## WARNING!

**DAMAGE CAUSED BY INCORRECT LOADING, WIRING OR PHYSICAL DAMAGE WILL INVALIDATE YOUR WARRANTY**

### PLEASE NOTE:

- Please make sure to isolate the mains before you install your Smart Relay with Open/Stop/Close (LP82).
- This device contains sensitive electronic components; ensure that wiring is in accordance with the manufacturer's instructions.
- Please make sure not to wire your relay while it is live, as it will cause the Smart Relay with Open/Stop/Close (LP82). to fail.
- If in doubt, please contact our technical team, hire a Lightwave Pro installer, or consult a qualified electrician.

## Preparing for Installation

Please follow the electrical wiring instructions carefully to ensure the product is installed safely.

Neglecting to follow these instructions could result in the loss of your 2-year warranty on the device.

**Damage caused by incorrect wiring, any modifications, or physical damage will invalidate your warranty.**

LightwaveRF Technology Ltd cannot accept responsibility for any loss or damage that may occur if the instruction manual is not followed correctly.

**IMPORTANT:** Any electrical installation must comply with building regulations, BS 7671 (IET wiring regulations) or local equivalent.

**IMPORTANT:** If conducting an insulation resistance test, any hard-wired Lightwave devices must be disconnected from the mains, or damage to the unit may occur.

**IMPORTANT:** High-Power inductive loads can potentially damage the device and are not recommended.

### You will need:

- Choose a safe location for the relay
- Suitable electrical screwdrivers.
- Your link Plus Hub and smartphone.
- The Lightwave Link Plus App can be downloaded. (available on iOS & Android)
- It is important to isolate the mains before wiring the relay
- We recommend capturing photographs of your current wiring setup to assist you in properly installing the relay
- A Waterproof housing if installing outdoors

### What is included in the box:

- Smart Relay with Open/Stop/Close (LP82).
- Installation manual.

## Installing a Smart Relay with Open/Stop/Close (LP82)

If you plan to install this product yourself, please follow the electrical wiring instructions carefully to ensure the product is installed safely, if in any doubt please consult a qualified electrician, technical team or Lightwave Pro installer.

**It is important to install this product in accordance with these instructions. Failure to do so may risk personal safety, create a fire hazard, violate the law and will also void your warranty.**

LightwaveRF Technology Ltd will not be held responsible for any loss or damage resulting from not correctly following the instruction manual.

**PLEASE REMEMBER THAT LIVE ELECTRICITY IS DANGEROUS. DO NOT TAKE ANY RISKS.**

Turn off the mains electricity:

It is important to make sure that you turn off the mains power supply to your existing power circuit at the consumer unit.

Location

Prepare a suitable location by installing the Smart Relay in an enclosure to reduce the risk of contact with live wires, ensure it meets safety requirements, and allow access so it can be paired to the Lightwave app.

# Installing a Smart Relay with Open/Stop/Close (LP82)

The Smart Mini Relay can provide up to 500W of mains powered switching or volts free switching for circuits that do not require mains power.

It has three positions: 0 for no circuit, 1 for Circuit 1, and 2 for Circuit 2 (optional).

The relay always requires mains power to operate, so connect the live and neutral wires as shown in the diagrams.

Wire colours may vary and may not be labelled correctly, so if in any doubt, consult a qualified electrician or hire a Lightwave pro installer.

For more information, please click on the links:

[How to install a Smart Mini Relay \(LP82\)](#)

[Installation video of how to install a smart relay.](#)

## 2.1 Adding mains voltage to a circuit (Switching a single circuit)

In this case, mains voltage is 'jumped' from the main incoming line feed to the COM terminal by the addition of a connecting a 'jumper' wire.

Mains power can now be used to drive the single circuit illustrated in diagram 2.1

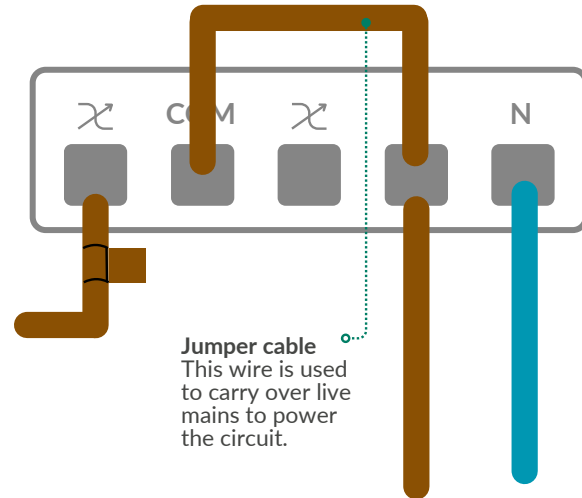

# Installing a Smart Relay with Open/Stop/Close (LP82)

The Smart Mini Relay can provide up to 500W of mains powered switching or volts free switching for circuits that do not require mains power. It has three positions: 0 for no circuit, 1 for Circuit 1, and 2 for Circuit 2 (optional).

The relay always requires mains power to operate, so please connect the live and neutral wires as shown in the diagrams.

Wire colours may vary and may not be labelled correctly, so if in any doubt, consult a qualified electrician or hire a Lightwave pro installer.

[For more information, please click on the links:](#)

[How to install a Smart Mini Relay \(LP82\)](#)

[Installation video of how to install a smart relay](#)

## 2.2 Switching between 2 circuits (blinds, gates, garage doors etc)

If a second connection to another circuit is attached to the second switched connection terminal, then the Relay can be used to toggle between the two circuits, this is commonly used for motor circuits driving blinds, gates, garage doors and more. When position 1 (blue) is selected, circuit 1 will be active. When position 2 (purple) is selected, circuit 2 will be active. There is also 'stop' position 0 (indicated by a red LED) which breaks contact with both of the right and left-hand circuits.

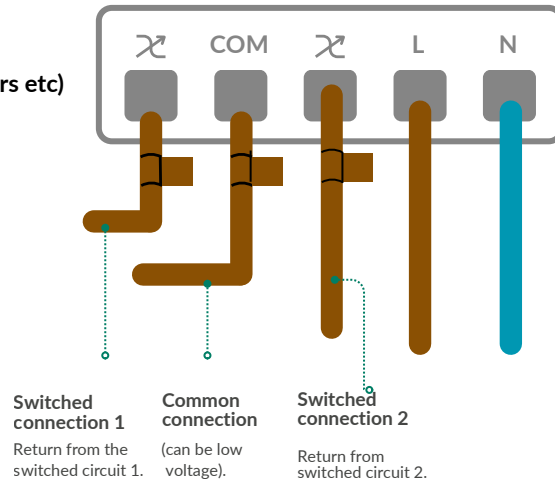

# Installing a Smart Relay with Open/Stop/Close (LP82)

The Smart Mini Relay can provide up to 500W of mains powered switching or volts free switching for circuits that do not require mains power. It has three positions: 0 for no circuit, 1 for Circuit 1, and 2 for Circuit 2 (optional).

The relay always requires mains power to operate, so connect the live and neutral wires as shown in the diagrams.

Wire colours may vary and may not be labelled correctly, so if in any doubt, consult a qualified electrician or hire a Lightwave pro installer.

For more information, please click on the links:

[How to install a Smart Mini Relay \(LP82\)](#)

[Installation video of how to install a smart relay](#)

## 2.3 Switching a single circuit

Use this configuration to switch a single circuit (can be low voltage) that does not require mains power to be provided from the Relay's line and neutral terminals.

When position 1 (blue) is selected then this circuit will be active.

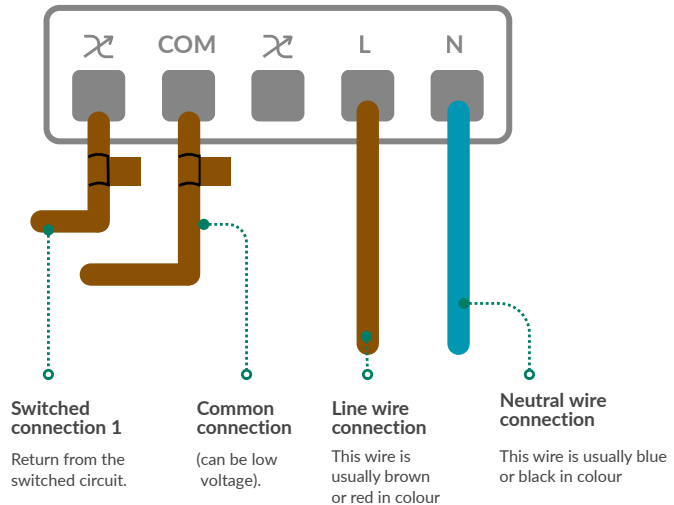

# Installing a Smart Relay to a Lightwave dimmer switch

The relay can be controlled wirelessly using a smart dimmer. This is useful for non-dimmable lights, extractor fans, and higher wattage circuits. **Do not connect the dimmer and relay using the dimmers Switched Live (X) terminal** as this will cause the relay to lose power when the dimmer is turned off.

**Diagram on how to wire up a relay to a dimmer switch:**

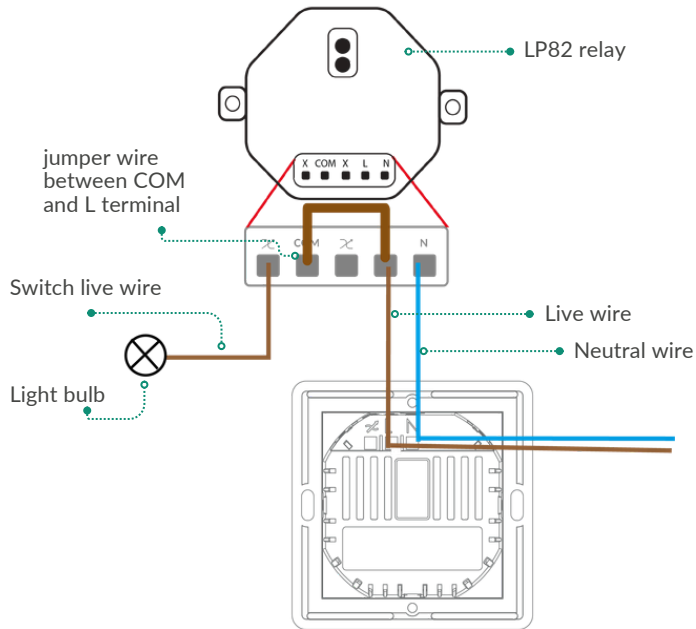

## Key:

X- Switch Live wire terminal

COM- Common terminal

L - Live wire terminal

N- Neutral wire terminal

## Pairing and Grouping the Dimmer and Relay

After following the wiring diagram, the lights can only be controlled from the relay. To use the dimmer, add both devices to the Lightwave app. Pair each device individually, then create a group automation to link them. See pages 13 to 14 for pairing and page 15 for group automation setup.

# How to pair a Smart Relay to the Lightwave App

**Before you begin:** Download the Lightwave Link Plus App from the Google Play Store or Apple App Store.

## Adding a smart relay to the Lightwave Link Plus App:

**Before you start,** ensure the Link Plus Hub is positioned high and centrally in the house for the best signal.

- Open the app and tap the green plus (+) button at the bottom of the page. Then select the devices icon.
- Enter a name for your device in the grey box that says e.g. Porch Spotlights.
- Put the device into linking mode by pressing & holding the link button located above the indicator light. While the device LED is flashing red/blue, tap Link in the app.
- The app will scan and pair with the device. Once linked, the LED will flash blue rapidly.
- After adding the device, please give it a name & assign it to a room in the app to make it easier to control and organise your devices.







### Linking mode:

- Press and hold the dedicated linking button until the LED flashes red and blue alternatively.

### Issue with pairing the device:

- If the device exits pairing mode too soon, repeat the button press to re-enter linking mode.
- If the LED flashes red only, the device's memory must be cleared with a master reset. (see below)

### LED Indicator Lights

-  → Relay is On
-  → Pairing Mode
-  → Successful Pairing
-  → Memory is Full
-  → Relay is Off
-  → Relay is Locked
-  → Relay is updating

# How to pair a Smart Relay to the Lightwave App







## How to master reset the device:

- Press and hold the small button on top of the relay (near the LED indicator).
- When the relay flashes red, release the button, then quickly press and hold it again.
- The relay will flash red more rapidly, then turn solid green—this indicates it is resetting.
- Once the relay returns to solid red, it is ready to be re-paired with the Lightwave Link Plus app.

## For more information, please click on the links below:

- [How to add devices to the Link Plus App?](#)
- [How to put your devices into pairing mode?](#)
- [How do I master reset Lightwave devices?](#)
- [How to add your dimmer switches to the Lightwave app](#)

## LED Indicator Lights

-  → Relay is On
-  → Pairing Mode
-  → Successful Pairing
-  → Memory is Full
-  → Relay is Off
-  → Relay is Locked
-  → Relay is updating

# How to Create a Group Automation for a Dimmer Switch and Relay in the Lightwave App

Please ensure that both the dimmer and relay have been added to the Lightwave app and named accordingly, so you can then create a group automation to allow them to communicate with each other wirelessly.

## How to Create a Group Automation:

- Log in to your Lightwave app using your account details
- Press the green plus (+) button at the bottom of the screen
- Select Automations
- You will then see a list of automation types. Please select Group
- You will be taken to a new screen asking you to choose a group type. Please select Switch, as this creates a simple on and off automation
- You will now be shown your rooms and devices. Please select the dimmer switch and the relay that you would like to link together. Each selected device will highlight orange to confirm it has been chosen
- Once you have selected all required devices, press the next button (top right hand corner)
- You will now see a grey box (for example “Evening Lights”). Please select this box and enter a suitable name for your automation, such as “Landing light”
- After naming the automation, press done (top right hand corner) to save it

You have now successfully created a group automation.

For more information, please click on the link below:







[How to set up a “GROUP AUTOMATION” Set up a Dimmer to wirelessly control a Relay or Socket](#)

[How to add your dimmer switches to the Lightwave app](#)

# Creating Automations

- Using the Link Plus and Lightwave App, you can create custom automations for the relay
- As long as the Link Plus Hub is still connected to power, your automations will continue to work even if you lose your internet connection.
- You need internet connection to create the automations.

## Types of automations you can create with a Smart Relay with Open/Stop/Close:

-  **Timer =** When you would like a device to operate at a set time and on certain days.
-  **Schedule =** It is recommended to use a schedule when you would like a device to operate certain times throughout the week and on specific days.
-  **If-Do =** This automation triggers another action. For example: when one light switches on, all lights in the house turn on.
-  **Group =** This can be used to make multiple devices 'copy' each other. Useful for controlling many devices in the same location by only interacting with one of them.
-  **Do =** Can be used to create moods/scenes. It works on-demand only, so requires execution via the Link Plus App or via Google Home, Apple Home or Alexa.
-  **Simulated Occupancy =** This can be used to schedule your lights to come on at random times throughout the day when you are not at home.

For more information, please click on the link: [Introduction to Automations](#)

# Troubleshooting

If your Lightwave relay isn't behaving as expected, the steps below cover the most common issues and how to resolve them.

## Device not linking to the app

- Check the device hasn't been added to the default room (if no room is selected, it goes to the top room on your rooms list automatically).
- Make sure the device is within close range of the Link Plus hub.
- If the LED flashes red when pairing, the device memory is full and will need clearing before it can be added.

Helpful Guides:

[Why Won't My Devices Pair to the Link Plus App?](#)

[Where is the best place to position my Link Plus Hub?](#)

## Linked but not working

If the device appears in the app but doesn't respond, it may be paired as a Connect Series device.

What to try:

- Delete the device from the app.
- Clear the memory of the device.
- Put it back into pairing mode.
- Re-add it as a Smart Series device.

Helpful Guides:

[How to put your devices into pairing mode?](#)

[How to delete a device from the Lightwave Link Plus app?](#)

[How to add devices to the Link Plus App](#)

# Troubleshooting

## Flashing red LED light when pairing

A flashing red LED means the device memory is full, usually after a failed pairing attempt.

To clear the memory:

- Press and hold the small button on top of the relay (near the LED indicator).
- When the relay flashes red, release the button, then quickly press and hold it again.
- The relay will flash red more rapidly, then turn solid green—this indicates it is resetting.
- Once the relay returns to solid red, it is ready to be re-paired with the Lightwave Link Plus app.

Helpful Guides:

[How do I master reset Lightwave devices?](#)

## Flashing purple light

A flashing purple light means the device is locked.

To unlock it, open the Lightwave app, select the device, go to the lock option, and tap the lock icon.

Helpful Guides:

[How to Use the Lock Feature to Disable Hardware Controls?](#)



We've just launched our new Lightwave installation manuals and would love to hear what you think!

Your feedback helps us improve our guides and provide better support, whether it's something you liked or something we could make clearer. It only takes a few minutes and really makes a difference.

[Please click here to share your feedback](#)

Thank you for helping us improve your Lightwave experience.