



# PIR Sensor

LW107

Instruction manual



[www.lightwaverf.com](http://www.lightwaverf.com)

# EC DECLARATION OF CONFORMITY

Responsible Authority:

LightwaveRF PLC,  
Innovation Campus Birmingham  
Faraday Wharf  
Holt Street  
Birmingham  
B7 4BB

Tel: +44 (0)121 250 3625  
Email: enquiries@lightwaverf.com

Model Number(s):

JSJSLW107

Description:

PIR Sensor

Directives this equipment

Complies with:

2006/95/EC The Low Voltage Directive N/A  
2004/108/EEC The Electromagnetic Compatibility Directive  
1999/5/EC R&TTE Directive  
93/68/EEC CE Marking Directive

Standards Applied in order to verify compliance

Safety: BS EN 60730-1: 2011

Health:

R&TTE: EN 301 489-1 V1.9.2: (2011-09), EN 301 489-3 V1.4.1: (2002-08)  
EN 300 220-1 V2.1.1: 2006, EN 300 220-2 V2.1.2: 2007  
EMC: EN 301 489-1 V1.9.2: (2011-09), EN 301 489-3 V1.4.1: (2002-08),  
EN 55022: 2010, EN 61000-3-2: 2006 +A1: 2009 +A2: 2009 Class A,  
EN 61000-3-3: 2008, EN61000-4-2: 2009,  
EN 61000-4-3: 2006 +A1: 2008 +A2: 2010, EN 61000-4-4: 2012,  
EN 61000-4-5: 2006, EN 61000-4-6: 2009, EN 61000-4-11: 2004

For and on behalf of LightwaveRF PLC

-----  
Name  
Position

J Shermer  
Managing Director

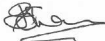

### How do I get started?

Please refer to the following installation and setup instructions that will guide you through the installation and setup process.

### How does it work?

The PIR will trigger a LightwaveRF device when it senses movement. It can be positioned anywhere (indoors). To install it, you will need simply to apply the adhesive strips provided and attach the PIR to a wall or flat surface. You can also mount the PIR to a standard back-box or flat surface using suitable screws (not included).

### Help video & further guidance

For additional guidance, and to watch a video that will help guide you through the installation process, please visit the support section on [www.lightwaverf.com](http://www.lightwaverf.com)



## Overview



**IMPORTANT:** Please retain these instructions for guidance on how to link other LightwaveRF receivers. For additional guidance please visit [www.lightwaverf.com](http://www.lightwaverf.com)

# Installation



**NOTE:** It is important to install this product in accordance with the following instructions. Failure to do so may void your warranty.

LightwaveRF is fully legal to install in your own home. However, if in doubt, always consult a qualified electrician.

## Inserting/replacing batteries & accessing sliders

To insert or replace the batteries, the main PIR unit must be removed from the base section. Removing the main unit from the base will also allow access to the rear sliders (which change the PIR settings) without having to detach the base from the wall once the PIR has been attached.

1. Carefully remove the frame by inserting a flat head screwdriver into the slot and lift away from the unit.

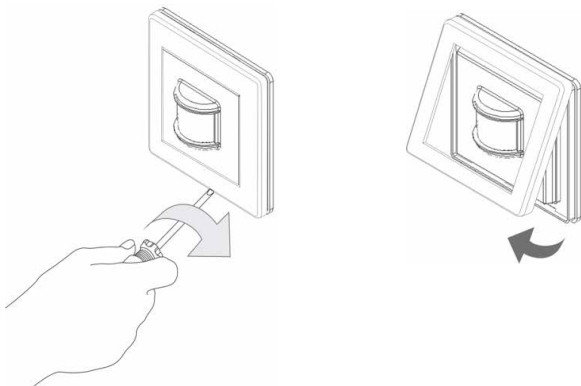

**2.** Insert the screwdriver under the tab situated at the bottom of the main unit as shown. Gently remove the main unit from the base.

**3.** The battery compartment is located on the rear of the main unit. Two AAA batteries are required to power the unit.

**4.** Replace the main unit and clip the faceplate back into place. Make sure that the faceplate hooks in from the top first. A sharp click will indicate that the plate has been successfully replaced.

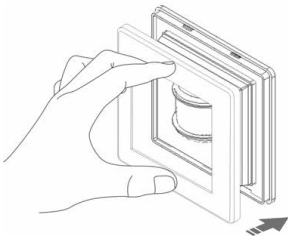
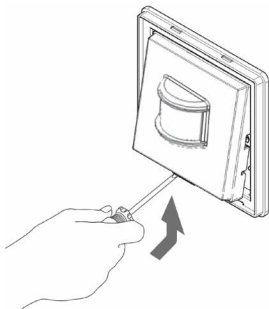

## Setting the detection angle

Setting the detection angle will determine the area in which the presence of movement will trigger the PIR. This angle can be altered by adding the lens covers that partially cover the sensor lens.

Vertically, the maximum detection angle is always 65 degrees. Horizontally, the maximum detection angle is 80 degrees without lens covers and 20 degrees with the lens covers.

The lens covers can be cut in order to alter the angle of detection. The more that is cut away, the wider the detection angle.

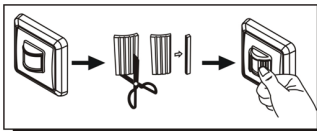
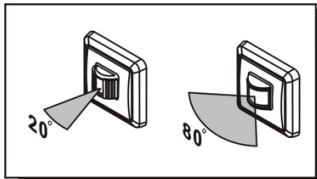
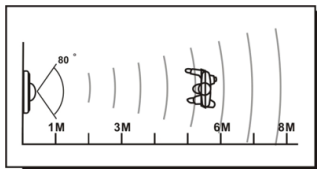



## Wall mounting the PIR

The PIR is designed to be wall mounted (although it can be positioned anywhere indoors) using the adhesive strips provided or suitable screws.

**NOTE:** Before permanently mounting the PIR, it is important to ensure that the location is suitable for the nature of the operation required and that the unit is setup and working as desired.

To mount the PIR, insert suitable screws into the mounting holes and screw to the wall. The main unit must be removed from the base in order to perform this task. Alternatively, place the adhesive strips along the rear sides of the surround and attach to the wall.

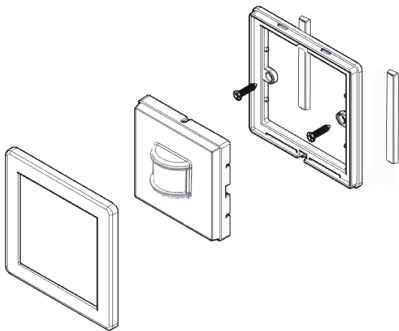

## Setup

The PIR sensor will trigger any LightwaveRF receiver, such as a dimmer switch or a power socket, to which it is 'linked'. It is possible to link a PIR to as many LightwaveRF devices as desired as long as they are within its range (approx. 10-15m indoors under normal conditions).

### Linking the PIR to a LightwaveRF device

1. Place the LightwaveRF device that you wish to control in 'linking' mode. For information on how to do this please refer to the instruction manual for that specific LightwaveRF device.
2. Whilst the LightwaveRF device is in linking mode, move the slider marked 'Learn' on the rear of the PIR to its opposite position. The LED light on the target device will flash to confirm that the PIR is linked. This process can be repeated to control multiple devices from one PIR.



Learn  
slider

## Unlinking the PIR from a LightwaveRF device

1. Place the LightwaveRF device that you wish to remove in 'linking' mode. For information on how to do this please refer to the instruction manual for that specific LightwaveRF device.
2. Whilst the LightwaveRF device is in linking mode, move the slider marked 'learn' on the rear of the PIR to its opposite position. The LED light on the target device will flash to confirm that the PIR is unlinked.



Learn slider

## Sending 'on' or 'on & off' commands

Once the PIR is linked, moving the 'learn' slider to the position marked '1' will turn on any linked devices when the PIR is triggered. Moving the slider to the '1/0' position will turn on linked devices, but also send an 'off' command after a customisable delay period (see next section).

## Setting the 'off' command delay

If the learn slider is set to '1/0', then an 'off' command will be sent to a linked LightwaveRF device after the initial 'on' command sent by the PIR. The period of time between these two commands can be customised using the 'Time delay' slider. It has 4 positions: 5 sec/1 min/5 min/10 min. The delay countdown will begin once movement is no longer detected after the initial 'on' command has been sent.



Time delay slider

## Setting the light sensitivity

Setting the light sensitivity on the PIR sensor determines the light level at which the PIR sensor will become active. The sensitivity can be set by moving the position of the lux slider marked 'H/M/L'.



Lux slider

The slider has 3 positions: 'H/M/L'.

- In position 'H' the PIR will be active at all light levels.
- In position 'M' the PIR will only become active at low daylight levels.
- In position 'L' the PIR will only become active in darkness (or very low light).

**NOTE:** When adjusting the Lux setting it may take up to 30 seconds for the PIR to acclimatise to the new light setting.

## Finalising setup

Once the PIR has been linked to its target LightwaveRF devices and the settings adjusted, it can be mounted in its final position. Once in position, it is important to allow at least 30 seconds for the PIR to acclimatise to the light level in its new environment. Until this process has taken place, the unit may not perform as expected.

## Battery low indicator

The 'battery low' indicator is positioned inside the sensor lens. If the battery is low, the indicator will blink after the PIR has sent a command to inform that the batteries need changing.



## 1. (Easy): Nighttime safety

Required: PIR / plug-in sockets or dimmer

A PIR can be set to be active only during the hours of darkness. You can therefore position the sensor on an upstairs landing or in a hallway and use it to automatically turn on a LightwaveRF dimmer or plug-in at night. If the kids get up to use the bathroom in the middle of the night, the sensor will be triggered and the hall light and bathroom can be set to automatically light up. Best of all, once they are safely back in bed, the PIR will automatically turn those lights off again.



**Problem:** *The PIR will not link to LightwaveRF devices.*

**Solution:** The PIR may be encountering interference or may be at the edge of its reliable range of operation. First, ensure that there are no large pieces of metal, very thick walls or bodies of water in the path of the transmission. If the problem persists, try moving the PIR closer to the socket, or consider using a LightwaveRF Signal Booster to extend the range by relaying the signal between the PIR and target device.

**Problem:** *The PIR will not / no longer triggers any LightwaveRF devices.*

**Solution:** Change the batteries. A weak battery signal is indicated by a red LED light on the sensor lens illuminating after triggering. Please note: if the battery is totally expended, the red light may not illuminate so checking the batteries is always advisable even if no red light is visible.

**Problem:** *The PIR triggers randomly / unexpectedly.*

**Solution:** Check the battery strength: if the battery strength is low, the PIR can behave erratically. Alternatively, ensure that the field of vision of the sensor is not interrupted by anything that could move and/or emit heat (e.g. animals / spider on lens / heat rise from nearby radiator).

**Problem:** *The PIR still operates in daylight despite being set to only operate in darkness.*

**Solution:** The PIR sensor may be located in a dark or shadowy place despite the general light level being high. Consider repositioning the PIR.

**Problem:** *The PIR does not send the 'off' command after the specified delay period.*

**Solution:** The delay period countdown is only started once no more movement (heat based) is detected. It may be the case that the 'off' command is not being sent because the delay period is constantly being reset by further movement.

**Problem:** *A LightwaveRF device has been turned off manually after being triggered by the PIR, however, the PIR is now not working.*

**Solution:** Is there an automatic time delay set on the PIR? If so, even though the linked LightwaveRF devices have been turned off manually, the PIR will still be waiting to send an 'off' command. It will not turn on any devices again until the 'off' command has been sent after the set delay period has ended.



**Q. How long does the PIR battery last?**

**A.** This depends on use, but 9-12 months is a reliable average.

**Q. How do I know if the battery needs changing?**

**A.** A red light in the sensor lens will flash after the PIR has sent a command.

**Q. Can I control multiple devices with one PIR?**

**A.** Yes, you can link as many LightwaveRF receiver devices (such as dimmers and sockets) as you wish to the same PIR.

**Q. Can I have more time delay and light settings?**

**A.** No, only the settings denoted by the sliders are possible.

**Q. Can the PIR be mounted outdoors?**

**A.** The PIR is not waterproof, therefore this is not recommended.

**Q. Is it legal for me to install LightwaveRF devices myself?**

**A.** Yes, Lightwave products are fully legal to install in your own home.

**Q. Is it common for the sensor to be accidentally triggered?**

**A.** All PIR sensors can be accidentally triggered, however they work by detecting heat, rather than movement, so people and larger animals will trigger the sensor, whereas other objects generally will not.

## Specification

**RF frequency:** 433.92 MHz

**Output rating:** 3V

**Batteries:** 2x AAA

**Mounting:** Standard single back-box, sticky pads or screw to wall

**Dimensions:** Width 88mm, Height 88mm, Depth 27mm

**Warranty:** 2 year standard warranty



Lightwave<sup>RF</sup>

Innovation Campus Birmingham  
Faraday Wharf  
Holt Street  
Birmingham  
B7 4BB

